

Motorenfabrik Hatz GmbH & Co. KG
Ernst-Hatz-Str. 16
94099 Ruhstorf a.d. Rott
Germany
Phone +49 8531 319-0
Fax +49 8531 319-418
marketing@hatz-diesel.de
www.hatz-diesel.com

CREATING POWER SOLUTIONS.



1D81C Aircon APU

702 528 45 EN-03.16-0.5 Printed in Germany
We reserve the right to make all changes that
serve technical development.



Hatz Systems - Made in Germany



CREATING POWER SOLUTIONS.

www.HATZ-DIESEL.com

Keep a cool head with innovative solutions from Hatz Systems

Hatz Systems underscores its competence in the development of customized special solutions with a combination system, consisting of an air-conditioning compressor and generating set.

Based on a 1D81C, the Hatz Systems business division has developed a combined system that, in addition to an air-condition compressor, also contains a generating set. Fields of application for the Hatz Aircon APU are principally construction machinery and commercial vehicles powered by a heavy-duty engine. Inland waterway vessels are also perfectly suited for installation of the Hatz Aircon APU. The system can also be operated with different Hatz engines depending on the power requirement. On average, construction machinery is utilized between 30 and 50 % of the time in daily use, the heavy-duty engines run at idle speed during the remaining time. In addition to an average fuel consumption rising to 20 l/h, this also shortens the time between maintenance intervals. Trucks consume a comparatively large amount of fuel for stationary air-conditioning, for instance during the rest times. The air-conditioning system can be installed with the compressor operated by the Hatz Aircon APU and supply cool air to the driver's cab. At the same time the batteries for the large units can be charged, or power can be supplied to other consumers.

For this process, the combination unit needs only 2.1 l/h fuel. Additionally, noise emissions are just 74 dB [A] at a radius of 7 meters. The system furthermore contains a Multiflex instrument box with remote start function developed by Hatz which can be used to start the APU directly from the driver's cab or, in the final configuration level, even from a cell phone. The Multiflex is CAN bus compliant allowing integration in vehicle electronics.

Advantages of the Hatz Aircon APU

- Security against the non-idling laws that prevent engine-powered air-conditioning during idle times
- High saving potentials in operating costs: reduced fuel consumption of up to 16,000 liters diesel possible per year, as well as lower maintenance costs
- Redundant and self-sufficient energy supply possible
- Retrofit in existing machines possible with a proven amortization of 12-15 months
- Enhancement in vehicle value through shorter running times
- Simpler export and re-export to countries with high ambient temperatures

Scalable system

The Hatz Aircon APU system can be adapted to large and small engines according to the cooling requirement and existing installation space. The base system always remains the same: A small, efficient, air-cooled Hatz diesel engine operates an air-conditioning compressor and an alternator for power supply. Depending on the cab size, outside temperature and required indoor temperature, the necessary cooling capacity and respective compressor size can be calculated. The electrical system of the carrier vehicle determines the battery charging current. The optimum Hatz diesel engine is integrated in the system in line with the calculated power requirement.

1D81C	
Size [cm, WxHxD]	53x59x51
Weight [kg]	118
Power [kW]*	9.1

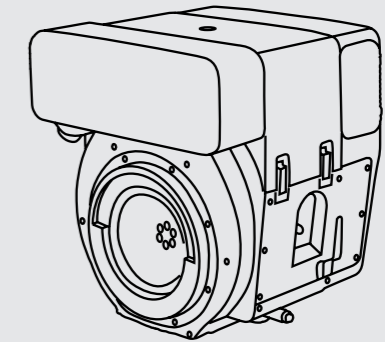

Aircon module	
Size [cm, WxHxD]	52x30x25
Weight [kg]	85

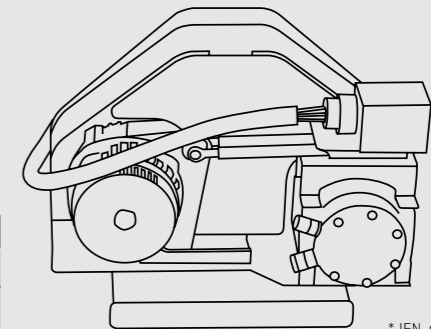

* IFN-rating @ 2750 min⁻¹
All measures are approximate values

Performance data	1D81C Aircon
COP	1,75
Cooling capacity [kW]	8,0
Charging current [A]	55

Configuration examples. Other engine variations and performance data possible.

Technical data		1D81C Aircon APU
Engine	1D81C	Single cylinder diesel with direct injection
	Displacement [cm ³]	667
	Compression ratio	20.5:1
	Rated speed [rpm]	2750
	Power at rated speed [kW]	9.1
	Consumption at rated speed [l/h]	approx. 2.1
	Emission standard	EPA Tier 4 final
Alternator	Voltage [V]	24
	Current [A]	55
Compressor	Displacement [cm ³ /rpm]	154.1

Simple integration

The 1D81C Aircon APU has compact dimensions, a low weight, and many more reasons allowing integration in existing machines. The alternator and compressor are driven by a centrifugal clutch and a poly V belt.

